

Precision Storage Vessels



CHILLED WATER BUFFER TANKS



CE EN ISO 9001: 2000

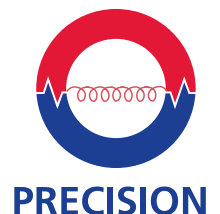

PRECISION

Chilled Water Buffer Tanks

Chilled water buffer tanks are designed, to be used with chillers which do not have sufficient water volumes as required by the chiller.

Chillers are designed to operate with a minimum water volume, which typically ranges from 22 litre to 38 litres per ton for air conditioning application, for to get better temperature accuracy.

Most of the chiller compressors can only start 3 to 4 times per hour. If the compressor is off and if there is a demand for chilled water the compressor cannot get on immediately. Without chilled water, building will not get the required cooling. To solve this problem chilled water buffer vessels are added in the system. These tanks increase the capacity of the chilled water in the system and stabilize the return water temperature. This ensures chilled water is always readily available there in the system.

Standard Equipment:-

- Tank manufactured as per ASME Standard
- Ring supports
- Internal Baffle
- Air vent
- Insulation and cladding (optional)
- Material A36 (other materials consult factory)
- Flanged connection (inlet and outlet)
- Manhole (optional)
- Tank will be externally sandblasted to SA 2.5 and then coated with two coats of red oxide primer.
- Horizontal configuration also available .
- Manufacturers data report for pressure vessels from U-1A as required by the provisions of ASME code will be furnished for each chilled water buffer tank.
- Working pressure 10 bar, 16 bar, 25 bar Test pressure 15 bar, 24 bar , 38 bar
- Plate Thickness are in excess to relevant codes.

Formulas used for determining the correct chilled water buffer tank :-

1. Required System Volume = (Chiller tons) × (Recommended system volume / ton)
2. Actual System Volume = (Piping volume) + (Terminal equipment volume)
3. Tank Size required = (Required system volume – Actual system volume)

CHILLED WATER BUFFER TANK

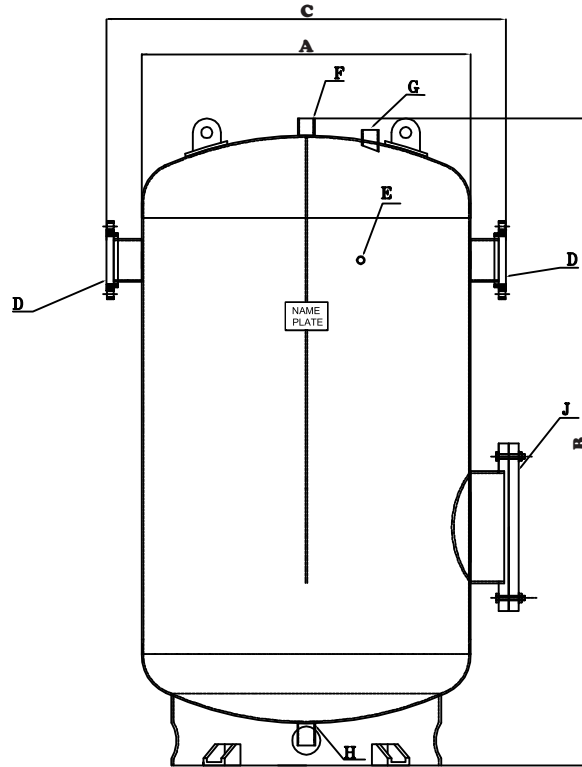

Capacity	A	B	C	D	E	F	G	H	I	J
Litres	mm	mm	mm	Flanged					Handhole	Manhole
220	450	1700	688	2"	½"	¾"	¾"	1"	4" x 6"	-
500	660	2080	907	3"	½"	¾"	¾"	1"	4" x 6"	-
1000	860	2230	1108	3"	½"	1"	1"	1 ½"	4" x 6"	-
2000	1170	2110	1420	6"	½"	1"	1"	1 ½"	-	16"
3000	1260	2930	1510	6"	½"	1"	1"	1 ½"	-	16"
4000	1450	3025	1700	6"	½"	1"	1"	1 ½"	-	16"
5000	1600	3100	1850	6"	½"	1"	1"	2"	-	16"
6000	1600	3600	1858	8"	½"	1"	1"	2"	-	16"
7000	1600	4100	1858	8"	½"	1"	1"	2"	-	16"
8000	1650	4375	1908	8"	½"	1"	1"	2 ½"	-	16"
10000	1650	5375	1908	10"	½"	1"	1"	2 ½"	-	16"

* Other capacities and working pressure available consult factory.

* Other dimensions available consult factory.

RANGE OF PRODUCTS

- ✦ HEAT EXCHANGER PACKAGE
- ✦ AIR RECEIVER
- ✦ OIL AND GAS FIRED WATER HEATERS
- ✦ INDIRECT HEATED STORAGE CALORIFIERS
- ✦ AIR SEPARATORS
- ✦ FEED TANKS & CONDENSATE RECEIVERS
- ✦ BLOWDOWN VESSEL
- ✦ ELECTRIC WATER HEATERS
- ✦ BUFFER VESSELS

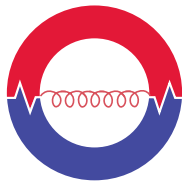

PRECISION

Precision Storage Vessels Pvt. Ltd.

Kalpadi, P.O.
Kalpadi, K. K. Dist.
Tamil Nadu, India
Tel : 0091 4651 237730
Fax: 0091 4651 238585

email: manuel@psvpl.com



PRECISION

Precision Storage Tanks LLP

3rd Floor 82 King Street
Manchester MZYWQ
United Kingdom
Tel : 0044 161 8 325 080
Fax: 0044 161 8 352 323